

UNITED®

DRINK MIXER MANUAL



Model: CM-6059

GENERAL SAFETY INSTRUCTIONS

1. **This appliance is designed for domestic use only.** No responsibility is accepted for damage resulting from use non-compatible with the instructions.
2. The device is used only for coffee, various cocktails, sauce vinaigrette, baby food, milk shakes etc.
3. Do not operate the appliance if the power cord shows any signs of damage. If the supply cord is damaged, it must be repaired by a qualified person in order to avoid a hazard. Improper repairs may place the user at serious risk.
4. Always handle the power cord with care. Do not pull or strain the power cord. The power cord may never be folded or pinched. Always pull the plug to disconnect the power cord, never pull on the cord to disconnect it.
5. Do not let the cable resting against a hot surface or hanging on the edge of the table.
6. Do not immerse the appliance in water or any other liquids.
7. Do not operate the appliance with wet hands.
8. Do not use any accessories not recommended by the manufacturer. It may cause injury and device destruction.
9. The device should always be disconnected from the mains when not in use. Always switch OFF ('0' position) and unplug the appliance if it is not in use and before moving, cleaning and/or assembling or disassembling it.
10. Before disconnecting the device from the socket, press the powder button in position 0 / OFF.
11. Never insert your fingers or any other objects (hair, clothes, cooking utensils, knives, screw drivers etc.) near the axle when the appliance is in use.
12. Children should be supervised to ensure that they do not play with the appliance.
13. Read all the instructions carefully before you use the appliance and keep them for future use.

14. This appliance is not intended for use by persons (including children) with reduced physical, sensory or mental capabilities, or lack of experience and knowledge, unless they have been given supervision or instruction concerning use of the appliances by a person responsible for their safety.
15. Children should be supervised to ensure that they do not play with the appliance.
Children of less than 3 years should be kept away unless continuously supervised.
Children aged from 3 years and less than 8 years shall only switch on/off the appliance provided that it has been placed or installed in its intended normal operating position and they have been given supervision or instruction concerning use of the appliance in a safe way and understand the hazards involved.
Children aged from 3 years and less than 8 years shall not plug in, regulate and clean the appliance or perform user maintenance.

ADDITIONAL SAFETY PRECAUTIONS

1. Fingers and/or foreign objects should not be put into the mixing cup while in operation.
2. The blade is very sharp. Handle with extreme caution.
3. Always make sure the Milkshake Maker is securely in place before the motor is switched on.
4. Turn the switch to the "0" position after every use.
5. Do not leave the appliance unattended whilst in operation.
6. Do not use this appliance for anything other than its intended use.
7. Never operate the product when the cup is empty and do not remove the cup lid before the blade come to a complete stop.
8. Unplug from outlet when not in use, before putting on or taking off parts and before cleaning.
9. Avoid contact with moving parts.
10. **Warning:** Care is needed when handling blades, especially when the blade needs to be cleaned.

OVERVIEW

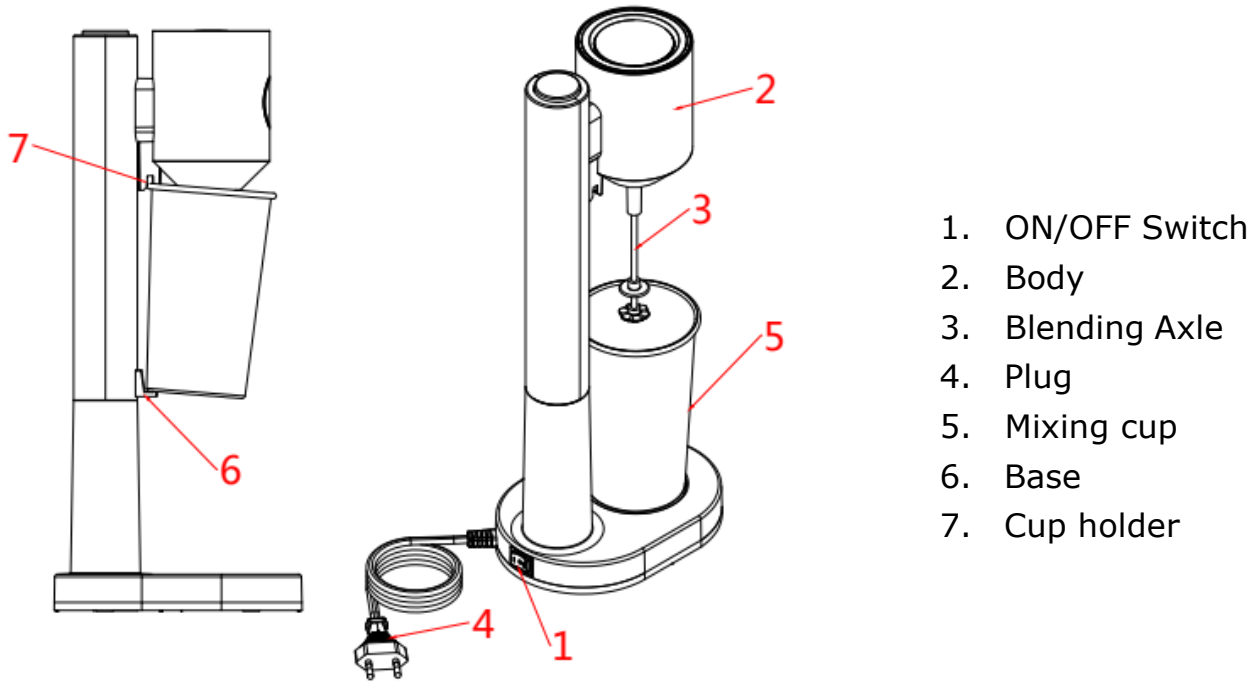

PRECAUTIONS AND FEATURES

- The switch should be on the "0" position before inserting the plug into a suitable power supply.
- Turn the power switch to be "I" or "II" position.
- Pour milk into the provided plastic cup.
- Add Milkshake flavour powder and sugar (or any other ingredients that you prefer) to the mix.
- Place the cup between the holder (7) and the base (6).
- The Milkshake Maker should be switched on for not more than 1 minute on every operation.
This will ensure the desired results.
- Turn the switch to the "0" position and let the Milkshake Maker cool for approximately 2 minutes.
- Always keep the Milkshake Maker dry.

BEFORE USE

1. Ensure the packaging of this appliance is disposed of properly. Keep plastic bags away from babies and children.
2. After you remove the device from its packing, clean it with a damp cloth.
3. Never immerse the appliance in water, in order to clean it.
4. Ensure that the main voltage rating of your power supply corresponds to the voltage requirements of the appliance.
5. Place the device on a flat and dry surface.
6. Make sure that all parts of the device are properly mounted before using the appliance.
7. Do not switch the appliance on without the cup in place.
8. Before using the device, please unfold the cord completely and make sure that it does not show any sign of damage.
9. Do not use the device for more than 1 minute continuously. Be sure to always do a pause of 10 minutes between each use.

CARE AND CLEANING

1. Before cleaning: the switch must be in the "0" position and the power plug must be disconnected from the mains supply.
2. Do not immerse the Milkshake Maker in water or other liquid. Simply wipe with a damp cloth.
3. To clean the axle, pour water into the cup and switch on for a few seconds.
4. Do not store the Milkshake Maker immediately after use as it might still be hot.
5. Allow to cool and then store in safe place.

STORAGE

- Store the Milk Shake Maker after it has cooled down gradually.
- When not in use, disconnect the Milk Shake Maker and store in a dry, safe place, out of reach of children.

ATTENTION!

- Do not place the appliance on, near or in microwave oven, electric oven or gas oven. Keep the appliance away from flammable objects or other heat source.
- The device should be used only by adults.
- Always supervise the device when it is in use.
- Always leave enough space around the device when it is in use, among other items. Do not place the device near flammable materials such as furniture, pillows, fabrics, curtains etc.
- Never blend hot oil or any other hot liquid.
- Never blend fat.
- Do not add ingredients in the cup while the appliance is operating.
- Do not move the appliance while it is operating.

NOTE:

The appliances are not intended to be operated by means of an external timer or separate remote-control system.

TIPS

- Do not overfill beaker beyond markings.
- For more volume, use low fat milk as full cream milk does not froth as much as low fat milk.
- Ice cream and fruit added will increase the volume of the milk shake.
- Chill ingredients before using them; this will add maximum volume to your drinks.

NOTICE ABOUT RECYCLING



Your UNITED product is designed and manufactured with high quality materials and components which can be recycled and reused.

This symbol means that electrical and electronic equipment, at their end-of-life, should be disposed of separately from your household waste.

Please dispose of this equipment at your local community waste collection / recycling centre.

In the European Union there are separate collection systems for used electrical and electronic products.

Please help us to conserve the environment we live in!

DECLARATION OF CONFORMITY

Herewith, we state that this product complies with the requirements of below directives:

EMC-Directive: 14 / 30 / EU

Low Voltage Directive: 14 / 35 / EU

CE Marking: 93 / 68 / EEC

RoHS Directive: 11 / 65 / EU & 15 / 863 / EU

The detailed declaration of conformity can be found at:

www.united-electronics.gr



KALLIOPI KARIDA & CO, LP

87A, 17is Noemvriou str

P.C. 55535, Pylaia, Greece

T: +30 2316 006600

www.united-electronics.gr